

CONNECTING PIPE  
6" OR LARGER DIA  
FIELD VERIFY DIAMETER,  
MATERIAL AND  
ORIENTATION SHOWN

FLEXIBLE, WATER-TIGHT  
BOOT PER NOTE 3

FLOW

A

A

CHANNEL SHALL BE FACTORY  
FORMED WITH SAME SLOPE, SIZE,  
DEPTH, AND SHAPE AS CONNECTING  
PIPE WITH SMOOTH FINISH -  
CHANNEL SHALL CURVE IN DIRECTION  
OF FLOW WITH UNIFORM RADIUS  
AND MINIMIZE DROPPING AND  
SPLASHING OF FLOW

2'-0" MAX.

FERNCO SHIELDED (STRONG  
BACK) RC COUPLING  
OR APPROVED EQUAL. PROVIDE  
FLUSH INVERT AND ENCASE IN  
CONCRETE. PROVIDE 4  
STAINLESS STEEL BANDS, 2  
BANDS EACH SIDE

PLAN

**NOTES:**

1. CONTRACTOR SHALL BE RESPONSIBLE FOR PROPER SLOPE AND CONSTRUCTION OF CONNECTING PIPE.
2. INVERT OF CONNECTING PIPE SHALL MATCH CROWN OF DISTRICT SEWER UNLESS OTHERWISE DIRECTED BY THE DISTRICT.
3. MANHOLE PIPE CONNECTIONS SHALL BE A FLEXIBLE WATER-TIGHT BOOT WITH MIN 2xSST BANDS ON PIPE PER BOOT PER ASTM C923 AND BE FACTORY INSTALLED UNLESS OTHERWISE APPROVED BY THE DISTRICT (KOR-N-SEAL, OR APPROVED EQUAL).

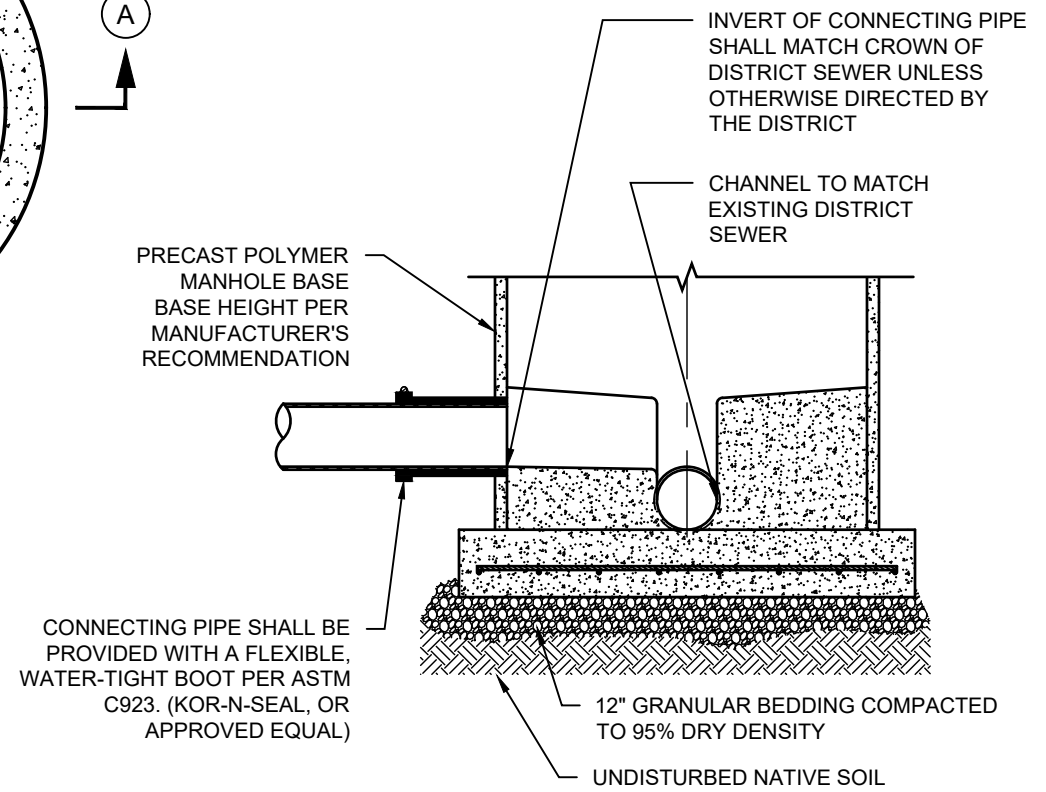

INVERT OF CONNECTING PIPE  
SHALL MATCH CROWN OF  
DISTRICT SEWER UNLESS  
OTHERWISE DIRECTED BY  
THE DISTRICT

CHANNEL TO MATCH  
EXISTING DISTRICT  
SEWER

PRECAST POLYMER  
MANHOLE BASE  
BASE HEIGHT PER  
MANUFACTURER'S  
RECOMMENDATION

CONNECTING PIPE SHALL BE  
PROVIDED WITH A FLEXIBLE,  
WATER-TIGHT BOOT PER ASTM  
C923. (KOR-N-SEAL, OR  
APPROVED EQUAL)

12" GRANULAR BEDDING COMPACTED  
TO 95% DRY DENSITY

UNDISTURBED NATIVE SOIL

SECTION A



**NORTH DAVIS SEWER DISTRICT**

**Standard Manhole Connection**